

VERTEX Water Products

EverCool BW-528X Bottled Water Cooler

Use and Care Manual

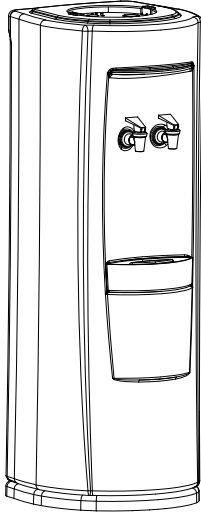

SPECIFICATION

Voltage	115V AC±10%/1PH/60Hz.
Size	(39.0 in.) H., (13.2 in.) W., (12.9 in.) D.
Shipping Weight	25.8 lb. for Cook/Cold model (approx.) 31.5 lb. for Hot/Cold model (approx.) 332.0 lb. for Hot/Cook/Cold model (approx.)
Refrigerant	HFC 134a

Specification subject to change without notice.

INSTALLATION

1. Locate water cooler in a well-ventilated space where temperature is always above freezing.
 2. Insure proper ventilation by maintaining a minimum clearance of 2.5" (61mm) on sides and rear of cooler. Make sure cooler is on a level surface.
 3. To prevent algae from growing, do not locate cooler near direct sunlight.
- NOTE: Do not use this cooler to chill or heat any liquids other than treated water. For POU model, the inlet water supply pressure should not exceed 70PSI.

START UP

1. Install drip tray below faucet.
2. Thoroughly clean the cooling tank and baffle. Baffle must be in place for proper cooling operation.
3. **For Non-WaterSafe Model** : Remove the cap from bottle, and invert the bottle on top of the unit. CAUTION: Avoid filing the water tank above the level normally maintained by the inverted bottle. **For WaterSafe Model** : Unit equipped with the WaterSafe system must be used with bottles that have a hygienic bottle cap. Remove the paper seal on the cap, invert the bottle and align the hygienic bottle cap with the feed tube. Pierce cap by applying a slight downward pressure on the bottle. DO NOT REMOVE CAP FROM BOTTLE! The hygienic cap will reveal itself when the bottle is removed.
4. Hold faucet handle down until air bubbles rise in water bottle. On hot models, depress hot faucet handle until water flow is continuous and clear. Connect cooler to electrical supply.

CAUTION: Hot tank must be filled with water before connecting to electrical source. **Children to be Supervised with adult to prevent get burnt.**

Note: Button rail shall always keep clean as buttons may get stuck or leak.

OPTIONAL COMPONENTS

A. Heater Switch

- Locate at the back of the cooler condenser at top left side.
- Turn 'ON' the switch during installation before able to get hot water.
- Turn 'OFF' the switch if hot water not required.

CLEANING

ALL PLASTIC PARTS ARE DISHWASHER SAFE

Bottle ring, drip tray and shell can be cleaned with any non-abrasive household cleaner. To prevent damage to plastic parts, avoid abrasive cleaning aids such as steel wool etc.

MAINTENANCE

Temperature Control (Cold Control): The thermostat is set to deliver water approximately 45°F. For colder water, adjust the screw on the thermostat clockwise. The thermostat is located at the rear of the cooler.

Temperature Control (Hot Control): The thermostat is set to deliver water at approximately 185°F and is not adjustable.

Lubrication: None required.

Condenser: To ensure optimum cooler performance, condenser must be maintained free of dust and lint. Condenser must be regularly inspected and cleaned with brush.

Drip Tray: The drip tray should be emptied and cleaned regularly. To remove, pull tray straightforward from the cabinet.

Replacing Water Bottle: Depress faucet handle(s) until air bubbles rise in bottle after each replacement, this will ensure optimum water level for proper operation.

Storage / Return Shipment: If the cooler is removed from service, the water must be completely drained from the system.

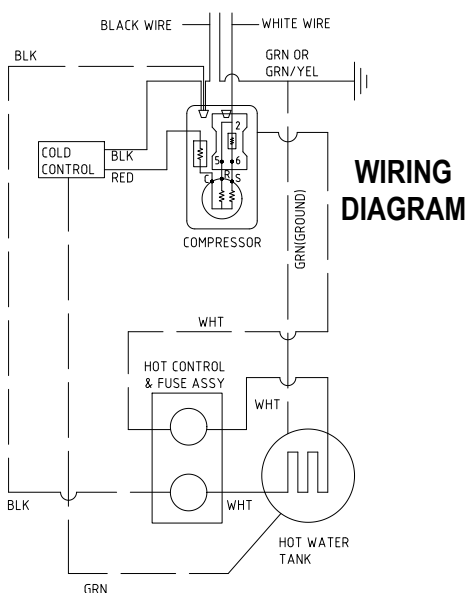

LIMITED WARRANTY

“BW-528X” WATER DISPENSER

Vertex Water Products (“Manufacturer”) sell its products through independent retailer dealers (“Dealer”) who resell to the end-user customer. In this limited warranty, “Vertex” refers to Vertex Water Products and not to the Dealer.

WHO IS COVERED BY THIS WARRANTY

This limited warranty covers only the first purchaser of the Vertex EverCool™ water cooler from a Dealer for use by that purchaser, and is not transferrable. “Consumer Use” means personal residential household use by a consumer or consumers. “Commercial Use” means all other uses, including (but not limited to) use for commercial, income producing purposes and/or when purchased by a business and/or when purchased for use in an office, business, or industrial setting. “Purchaser” means the end-user customer, and not a Vertex re-seller Dealer.

PERIOD OF COVERAGE OF THIS WARRANTY

Manufacturer warrants the complete water cooler (“the unit”) against defects in material and workmanship, subject to the exclusions described below, for a period of ONE YEAR, beginning on the later of either (a) the date of purchase or (b) the date of manufacture as identified by the Vertex unit’s serial number. Manufacturer additionally warrants the compressor for a period of THREE YEARS from the above date. The purchaser must provide the original sales receipt as proof of the date of purchase. If the purchaser is unable to produce the original sales receipt, the Warranty Period commencement date will be determined by Manufacturer, in its sole and absolute discretion, based upon the unit’s serial number. This warranty does not apply if the original serial number affixed by Manufacturer is removed, defaced, altered, obscured, tampered with, or obliterated. If Manufacturer provides a replacement part or parts, or repairs a part or parts, under this limited warranty, then the replacement part(s) or repaired part(s) will be covered under this limited warranty for the time remaining under the original Warranty Period applicable to the part(s) repaired or replaced.

The duration of **ALL OTHER WARRANTIES, INCLUDING ANY AND ALL IMPLIED WARRANTIES, INCLUDING BUT NOT LIMITED TO MERCHANTABILITY AND FITNESS FOR A PARTICULAR PURPOSE, ARE RESTRICTED TO THE TWO-YEAR LIMITED WARRANTY PERIOD.** Some states do not allow limitations on how long an implied warranty lasts, so the above limitation may not apply to purchaser.

WHAT IS COVERED BY THIS WARRANTY

This limited warranty covers defects in materials or workmanship, subject to the exclusions below and for the time period stated above. Manufacturer promises to repair or to replace, at Manufacturer’s sole and absolute discretion, any part of this water cooler that proves to be inoperative due to a defect in material or workmanship under normal use.

WHAT IS NOT COVERED BY THIS WARRANTY

This limited warranty does not extend to and expressly excludes:

- conditions, losses, malfunctions, or damages not resulting from defects in material or workmanship;
- conditions, malfunctions, losses, or damages or the inability to operate the Vertex unit resulting from conditions beyond Manufacturer’s control, including but not limited to failure of the unit or any of its parts due to damage caused by: improper installation; accident; fire; flood; windstorm; acts of God; rodent and/or insect infestation; vandalism; modification; alteration; combination with any other device or machine; abuse and/or misuse of the unit; negligence by purchaser or third parties; any part of the water system that has become fouled due to liming, dirt, unsatisfactory/unsanitary water conditions, corrosion, or faulty plumbing; failure to install, maintain, assemble, mount or place the Vertex unit in accordance with Manufacturer’s instructions and/or local, state, or national plumbing and electrical codes; wear and tear expected to occur in the normal course of use, including but not limited to cosmetic rust, scratches, dents or comparable and reasonably expected losses or damages; exposure to extreme variations in ambient environmental conditions (including but not limited to changes in heat, humidity, moisture, or exposure to sunlight).
- Labor for installation or de-installation of the unit or any of its parts; shipping of the unit or any of its parts to Manufacturer for repair/replacement.

In addition to the above exclusions, this limited warranty does not apply if any of the following conditions of operation are not met:

System Pressure 35 - 100 psi, Temperature 40 - 100 degrees F,

NO OTHER EXPRESS OR IMPLIED WARRANTY APPLIES

This limited warranty is the sole and exclusive warranty provided to the purchaser identified above. No other express warranty, written or verbal, applies. No agent, employee, deal or other person or entity is authorized to alter this limited warranty or make any other warranty on behalf of Manufacturer. The terms of this limited warranty shall not be modified by the Manufacturer, the purchaser/end user, or their respective successors or assigns.

WHAT WE WILL DO TO CORRECT PROBLEMS/ HOW TO GET WARRANTY PARTS

If the Vertex unit does not operate in accordance with the documentation provided to purchaser, or purchaser have questions concerning purchasers’ Vertex unit, please contact the Dealer from whom the unit was purchased. If the original Dealer is not available or the purchaser does not know who the Dealer is, please call or email the Manufacturer, Vertex, using the contact information provided below. We will try to find a Dealer in purchaser geographical area to assist purchaser. If a Dealer cannot be conveniently located, the Manufacturer, in its sole and absolute discretion, may offer two (2) options. First, we will attempt to troubleshoot the issue with purchaser over the phone. If the purchaser is comfortable making a repair/ replacing a part, once we understand the problem and its solution, we will send the replacement part(s) for the cooler. **This warranty is for the replacement**

of part(s) ONLY; it does not cover the cost of labor for either the Dealer or the end user/purchaser. The second option is that the end user/purchaser may, after notifying Manufacturer and receiving written authorization/ approval from Manufacturer to do so, send the unit back to Manufacturer and we will repair it. **The end user purchaser must pay the freight/ shipping costs to return the unit to Manufacturer.** Manufacturer will pay the freight/shipping to return the unit to the end user/purchaser following repair.

If the end user/purchaser contacts the Dealer and the Dealer repairs the unit pursuant to this limited warranty, Manufacturer will provide parts to the Dealer at no charge; labor is not included in this limited warranty. The Dealer may, in his or her sole and absolute discretion, decide to repair the unit on-site or take the unit to a shop to repair.

This limited warranty covers replacement or repair of parts only. Manufacturer will not replace the entire unit if a part can be replaced or repaired to restore the unit to full operational function. On the rare occasion that a unit cannot be restored to full operation by a part or parts, Manufacturer will replace the unit after the end user/ purchaser has shipped the unit to Manufacturer and Manufacturer has determined, in its sole and absolute discretion, that the unit cannot be repaired and must be replaced. **The end user/purchaser must pay the freight/shipping costs to return the unit to Manufacturer.** Manufacturer will pay the freight/shipping to return the unit to the end user/purchaser following repair or will ship a new unit if repair is not possible.

LIMITATION OF LIABILITY AND DISCLAIMER OF WARRANTIES

TO THE EXTENT PERMITTED BY LAW, IN NO EVENT SHALL MANUFACTURER BE LIABLE TO PURCHASER OR ANY THRID PARTIES FOR ANY INCIDENTAL, SPECIAL, INDIRECT, OR CONSEQUENTIAL DAMAGES, INCLUDING ANY ECONOMIC LOSS, WHETHER RESULTING FROM NON-PERFORMANCE, USE, MISUSE, OR INABILITY TO USE THE VERTEX UNIT. MANUFACTURER SHALL NOT BE LIABLE FOR DAMAGES CAUSED BY DELAY IN PERFORMANCE AND IN NO EVENT, REGARDLESS OF THE FORM OF THE CLAIM OR CAUSE OF ACTION (WHETHER BASED IN CONTRACT, WARRANTY, TORT, INFRINGEMENT, NEGLIGENCE, STRICT LIABILTY, OTHER TORT OR ANY OTHER LEGAL THEORY) SHALL MANUFACTURER'S ENTIRE LIABILTY EXCEED THE PRICE PAID BY THE ORIGINAL PURCHASER FOR THE VERTEX UNIT. THE TERM "CONSEQUENTIAL DAMAGES" SHALL INCLUDE, BUT NOT BE LIMITED TO, LOSS OF ANTICIPATED PROFITS, BUSINESS INTERRUPTION, LOSS OF USE OR REVENUE, COST OF CAPITAL , OR LOSS OR DAMAGE TO PROPERTY OR EQUIPMENT.

Contact information:

Vertex Water Products 5138 Brooks Street Montclair, California 91763. 800-627-2146 email: inquiries@vertexwater.com