



# ***PureWaterCooler***

## **Owners Installation Manual**

**PWC-8000**

**Ice-Making Cooler**



# Installation, Operation & Service Manual

## ICE & WATER DISPENSER

<b>PWC-8000</b>	SAFETY INSTRUCTIONS-----	3
	FEATURES & SPECIFICATIONS-----	5
	DISPENSER USE-----	7
	DISPENSER CARE-----	11
	INSTALLATION INSTRUCTIONS-----	15
	TROUBLESHOOTING-----	19
	SERVICE & WARRANTY NOTICE-----	22

### **GENERAL OPERATING INSTRUCTIONS**

**Read these instructions before use and save them for future reference.**

**Let the unit rest, unplugged and upright for 24 hours before use.**

- Remove all external and internal packaging materials. Be sure that all parts have been included before discarding any packaging materials. You may want to keep the packaging materials if taking the unit out of service or storage.
- Upon receipt and inspection of the unit, the power cord must be replaced if it is damaged.
- Prior to first use, the waterways must be flushed and sanitized. See page 7 for procedure and additional details.

## NOTICES AND SAFETY INFORMATION

To ensure proper and efficient operation of the PureWaterCooler Water Dispenser to your full satisfaction, carefully follow the instructions in this manual.

**Do not use with water that is microbiologically unsafe or of unknown quality without adequate disinfection before the system.**

Check and follow ALL applicable plumbing codes and ordinances when installing this equipment. Follow local codes if they differ from this manual.

**This dispenser has a maximum pressure rating of 100 psi. A pressure regulator must be used for all plumbed installations. This will help prevent internal structural damage to the unit and potential water leaks. The pressure regulator should be installed on the water supply before the inlet connection.**

Regularly inspect the filters, filter housings, the plumbing fittings and connections for water leaks. Water leaks may cause damage to your office or facility and are not the responsibility of the manufacturer.

**Only connect the power cord to a properly grounded outlet.** Note: This appliance is intended to be connected to a twenty amp fused/breaker circuit. Use of an extension cord will void all warranties.

Keep the power cord out of heavy traffic areas. To avoid a fire hazard, never put the power cord under rugs, near radiators, stoves or heaters.

Do not use a damaged power cord or plug. If the power cord is damaged, a qualified service technician must replace it.

**This dispenser is not intended for use by persons (including children) with reduced physical, sensory or mental capabilities, or lack of experience and knowledge, unless they have been given supervision or instruction concerning use of the dispenser by a person responsible for their safety. Children should be supervised to ensure that they do not play with the dispenser.**

This product should not be disposed with other household wastes. To recycle your used dispenser, contact your local recycler or waste collector for the proper procedures.

**Please dispose of properly**

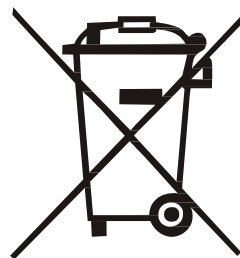

# SAFETY INSTRUCTIONS

## Electrical Safety

### DANGER

Improper use of the power cord plug can result in the risk of electrical shock, property damage and personal injury or death.

- This appliance is equipped with a 3-prong grounding-type plug, and shall be plugged into a properly connected grounding-type outlet.
- It is required that a 3-prong grounding-type electrical outlet properly grounded be used in accordance with the National Electrical Code and local codes and ordinances.
- A separate, adequately fused and grounded 20 amp circuit shall be used for this appliance. The voltage rating must match the rating label on the unit.
- Do not use an adapter or an extension cord.
- Do not, under any circumstances, cut or remove the third ground prong from the power cord.
- Never unplug the appliance by pulling the power cord. To disconnect the unit, always grip the plug firmly and pull straight out from the wall outlet.
- Do not operate the appliance if the cabinet housing is removed or damaged.
- Do not attempt to repair or replace any part of your appliance unless it is specifically recommended in this manual. All other servicing shall be referred to a qualified technician.
- To protect against electric shock, do not immerse appliance, plug or cord into water or other liquids.

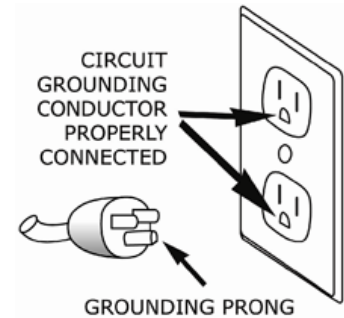

## Child Safety

- Exercise caution and use reasonable supervision when appliance is used near children. Never allow children to operate, play with or crawl inside the unit. Keep packing materials away from children.
- Keep fingers out of pinch point areas and be careful when closing doors if children are around.

## Hot Water Safety

### DANGER

This unit can dispense hot water. Hot water can scald your hands and body and cause serious injury.

- To avoid hot water spilling, always put a cup under the dispenser before you press the button to dispense hot water.

## Cleaning

<b>DANGER</b>	<b>To reduce the risk of injury when cleaning your appliance, follow these basic precautions.</b>
---------------	---

- Unplug the appliance or disconnect power before performing any maintenance or cleaning.
- Do not clean appliance with flammable fluids. Do not store or use gasoline or other flammable vapors or liquids in the vicinity of this or any other unit. The fumes can create a fire hazard or explosion.
- Do not use solvent-based cleaning agents or abrasives on the interior or exterior of the appliance. These cleaners may damage or discolor the appliance.
- Do not operate the appliance with wet hands, while standing on a wet surface or while standing in water.

## Moving

<b>DANGER</b>	<b>To reduce the risk of injury when moving your appliance, follow these basic precautions.</b>
---------------	---

- Exercise caution when moving and installing the appliance. The unit is heavy. To prevent strain or injury, it may require two or more people to move the unit.
- Remove all ice and drain all water before you transport the unit.

## Disposing of Unit

<b>DANGER</b>	<b>When disposing of refrigerated appliances, special handling is required. It is the consumer's responsibility to comply with federal, state and local regulations when disposing of this product.</b>
---------------	---

- Keep the carton, plastic bags and any exterior wrapping materials in a safe place where children cannot reach them. If you don't need these materials, destroy or recycle them. These items may cause suffocation to children.
- To avoid entrapment and suffocation, before you discard this appliance, remove the doors.



- 6. Drip Tray**
- 7. Storage**
- 8. Supply Inlet (for POU)**
- 9. Back Cover**
- 10. Power Cord**
- 11. Drain (for R/O installations only)**

- The dispenser allows you to enjoy cubed or crushed ice and hot or ambient water with the touch of a button.
- The two-evaporator cooling system and the ice freezer keep ice from melting and produces ice quickly.
- The bottled or POU supply option makes it perfect for all applications.
- Touch controls bring you the simplicity to select and dispense your preferred types of ice or water.
- Blue display and bright LED lights make it easy to use anytime and attractive to display anywhere.
- On/Off buttons for both ice and hot water allow you to save energy and give you the flexibility to activate them at your discretion.
- Automatic alerts for water and filter life (selection options 6/12/Off) will prevent you from running out of water and will alert you when it is time for filter changes.
- Dual action hot safety feature protects from accidental burning.

### Specifications and Dimensions

Model No	PWC-8000
Ice Type	Cubed and Crushed
Ice Production Rate (70°F Air/50°F Water)	Crescent Ice 22 lb / 24 hr
Ice Bin Capacity	11 lb
Water Type	Hot and Ambient Temperatures
Hot Water Temperature	185~195°F
Hot Water Capacity	1.8 L/hr
Operating Temperature for Ice	50~100°F
Water Supply	Bottled Water or POU
Storage Volume	3.5 cu ft
Electrical Rating	115V/60HZ, 5.6A
Unit Dimensions	18-1/8"W x 20-1/8"D x 58-5/8"H
Depth w/ Door Open 90 Degree	37"
Net Weight	120 lbs..

## DISPENSER USE

<b>DANGER</b>	Hot water can scald your hands and body and cause serious injury.
<b>CAUTION</b>	Do not use with water that is microbiologically unsafe or of unknown quality without adequate disinfection before the system.
<b>CAUTION</b>	Using water with high TDS levels may cause premature equipment failure. Preventative maintenance to prevent/remove mineral build up is required.
<b>CAUTION</b>	Do not store food and drink in the ice freezer.
<b>NOTE</b>	Prior to first time use, allow 24 hours to produce the first batch of ice. Discard the first three batches of ice produced.
<b>NOTE</b>	This dispenser has a maximum pressure rating of 100 psi (5.5 bar). A pressure regulator must be used for all installations. This will help prevent internal structural damage to the unit and potential water leaks. The pressure regulator should be installed on the water supply before the inlet connection.
<b>NOTE</b>	It is required that the waterways be sanitized prior to usage. Use your normal sanitizing solution or 1 TBSP of unscented bleach per gallon of water with a 5 minute contact time. Flush the water system after sanitization by dispensing at least 5 gallons of water through the machine. It is important to flush and sanitize the system after filter changes and prolonged periods of non-use.



## Indicator and Display Functions



Water heater indicator



Low water level indicator



Hot water temperature display

## Use of the Dispenser

- Once the unit is powered, if bottled water is selected, the water pump works immediately to pump water from the bottle to the water tank. If the filtered or R/O water supply option is selected, the water inlet valve opens immediately to let water flow into the water tank.
- Once the water tank is full, the icemaker and water heater will start working immediately. If the water tank is not filled with water within the time limit for the respective selection, the "Low" indicator will appear, and then the water pump, water inlet valve, water heater, icemaker and water dispenser will stop working.
- While the water heater is on, the "Heating" indicator will appear and the water temperature will be displayed.
- The cooling system will auto-start in 5 minutes. The cooling system will stop, automatically when ice is being ejected.
- See the Ice/Hot on/off instructions on next page.

## Turning the icemaker function on/off

The Icemaker function switch is located on the rear of the unit. The switch is shipped in the off position.

- Press the “Ice” switch to turn the Icemaker off.

## Turning the hot water function on/off

<b>NOTE</b>	<b>The hot water function can be turned off to save energy.</b>
-------------	---

The Hot water function switch is located on the rear of the unit. The switch is shipped in the off position.

- Press the “Hot” switch to turn the Icemaker off.

## Turning the Light on/off



Light & Reset button

- Press the “Light/Reset” button once to turn the task light on. The light will automatically turn off in 5 minutes; press the button again to turn it off.

## Dispensing hot water

<b>NOTE</b>	<b>If the “Hot” button is pressed without unlocking, continuous short beeps will be heard. The “Hot” button will be locked automatically once the button is released.</b>
-------------	---



Hot water dispensing button



Hot water unlocking button

- Place a cup under the water dispenser.
- Press the “Hot Water Unlock” button once. You will hear a long beep indicating the “Hot” button is unlocked and the display will indicate “Hot.”
- Then press and hold “Hot” button within 5 seconds to dispense hot water. While dispensing, the display will show the hot water temperature in degrees Fahrenheit.

## Dispensing ambient temperature water



Ambient water dispensing button

- Place a cup under the water dispenser.
- Press and hold the "Ambient" button to dispense room-temperature water.

## Dispensing ice

<b>NOTE</b>	<b>The ice dispenser will stop working while the freezer door is open. If ice cubes haven't been used for several days, they may freeze together and not dispense. If this happens, remove the ice bin, shake it, then push it back in.</b>
-------------	---

<b>NOTE</b>	<b>The ice dispenser is designed for rapid filling. Make certain that the intended container is located directly under the dispenser outlet. A quick press and release is all that is needed for a single fill container.</b>
-------------	---

## Dispensing cubed ice



Cubed ice dispensing button

- Place a cup under the ice dispenser.
- Press and hold the "Cubed" button to dispense cubed ice.

## Dispensing crushed ice



Crushed ice dispensing button

- Place a cup under the ice dispenser.
- Press and hold the "Crushed" button to dispense crushed ice.

## Replacing water bottle or checking water supply line



When the "Low" indicator appears, water dispensing valves, water pump and water inlet valve will stop working automatically.

- Check if the water bottle is empty and replace it.
- Check if the water supply line (for POU installations) is producing water and make repairs if needed.
- Press and hold "Lamp/Reset" button for more than 3 seconds until you hear a long beep to activate the water pump or inlet valve. This is required when replacing an empty bottle.
- The "Low" indicator will disappear automatically once the water tank is filled with water.

## Replacing water filters

### CAUTION

It is recommended that all water filters be replaced at the same time. The filters should be replaced as per the manufacturer's guidelines, typically at least once a year.

**FLr** When "FLr" flashes, replace the water filters as soon as possible.

- Reset the "FLr" status by pressing and holding "Lamp/Reset" button for 6 seconds until you hear a long beep and the "FLr" disappears.
- Dispense water for several minutes to flush the system until water is clear.
- To change the filter settings from the 12 month default, the dip switches on the circuit board will need to be adjusted.

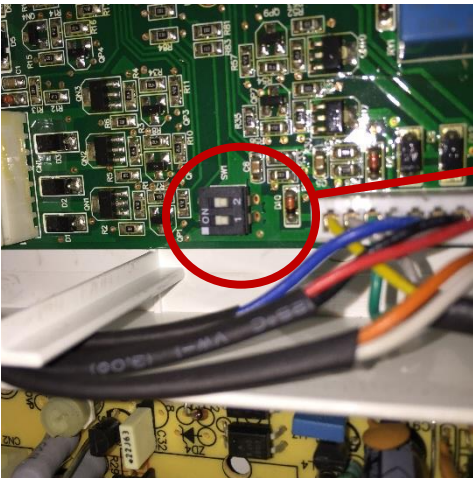

For 12 months (DEFAULT):

1 & 2 are set to **OFF**

For 3 months:

1 is set to **ON** and 2 is set to **OFF**

For 6 months:

1 is set to **OFF** and 2 is set to **ON**

To turn off notification:

1 & 2 are set to **ON**

## DISPENSER CARE

### DANGER

Unplug the unit or disconnect power before performing any maintenance.

### CAUTION

If ice cubes block the feeler arm, clear the ice cubes before you pull out the ice bin.

Move the feeler arm up and keep it above the ice bin while you pull out the ice bin. Otherwise the feeler arm may be damaged if it is obstructed by the ice bin.

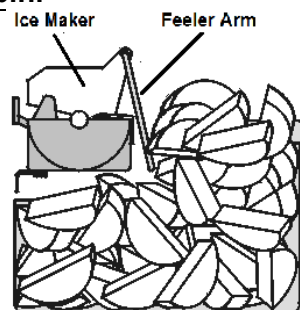

## How to empty the ice bin

- Use the following instructions to remove the ice bin when emptying ice or when cleaning the ice bin.

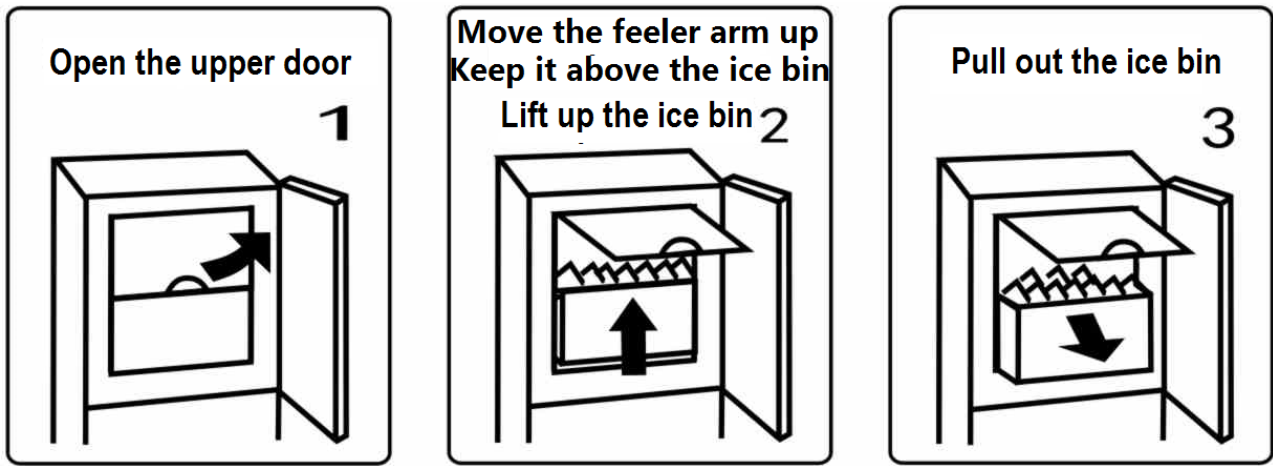

- Push the ice bin back until the auger is engaged in the auger coupler. If it is stuck, rotate the auger 1/8 turn, then push it in again.

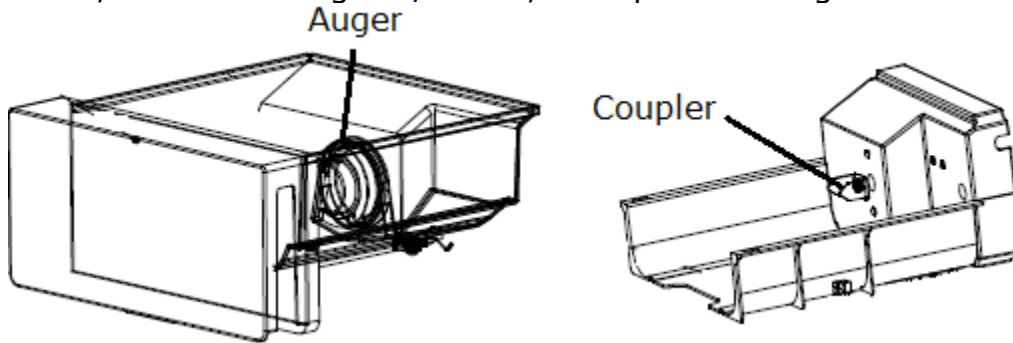

## How to drain water from the unit

- Use the water release drain located in the storage compartment to drain the water left in the unit.

## How to remove condensate

- The unit is operated with an automatic defrost cycle. Water collects in a water tray that is located in the compressor compartment. Normally, the water evaporates as part of the refrigeration cycle.
- Empty the water if the tray is full.

## **Cleaning the water system with citric acid if scale has built up**

For a bottled unit:

- Fill a 5 gallon bottle with cold water and add 8 oz of citric acid powder and install the bottle adapter.
- Wait for hot water to be ready. Dispense both ambient and hot water to flush the system. Repeat this procedure until the bottle is empty.
- Drain the remaining water through the release drain.
- Fill the bottle with clean cold water and install the bottle adapter.
- Dispense both ambient and hot water to rinse the system until water is clear.
- Drain any remaining water.

For a POU unit:

- Fill a 5 gallon bottle with cold water and add 8 oz of citric acid powder.
- Insert a ¼" OD tube to the line connector located at the back of the unit, and insert another tube end into the bottle near the bottom.
- Place the bottle above the unit so the water in the bottle can flow into the internal water tank by siphon.
- Wait for the hot water to be ready. Dispense both ambient and hot water to flush the system. Repeat this procedure until the bottle is empty
- Release the remaining water through the release drain.
- Fill the container with clean cold water.
- Dispense both ambient and hot water to rinse the system until water is clear.
- Release the remaining water.

### **When the "Low" indicator appears**

- Check water selection switch first.
- If bottled water is used, check if the water bottle is empty and replace it,
- If POU supply is used, check and ensure adequate water supply.
- Press and hold "Lamp/Reset" button for more than 3 seconds until you hear a long beep to activate the water pump or inlet valve.

### **If heavy frost builds up in the ice freezer**

- Press and hold the "Hot" button for more than 10 seconds until dEF is displayed and flashing. dEF will stop flashing when the defrost cycle starts.
- Once the defrost cycle is complete, the hot water temperature will be displayed.

### **If ice cubes are frozen together**

- Press the “Cubed” or “Crushed” button to dispense ice for a few minutes.
- Open the upper door and pull out the ice bin to shake it to break apart cubes or remove the large clumps of ice cubes.

### **If the ice bin is stuck**

- Unplug the unit.
- Use a hair dryer with warm or cold air to melt the ice.
- Pull out the ice bin and empty it.
- Wipe up water and put the ice bin back.
- Plug in the unit.

### **If ice cubes are jammed in the icemaker**

- Unplug the unit.
- Use a hair dryer with warm or cold air to melt the jammed ice cubes.
- Remove the jammed ice cubes.
- Plug in the unit.

### **If a power outage happens**

- Unplug the unit.
- Pull out the ice bin and empty it.
- Wipe up water and put the ice bin back.

### **If you are away on holidays or vacations**

- Unplug the unit or disconnect the power.
- Open the upper door
- Pull out the ice bin and empty it.
- Let the freezer defrost.
- Wipe up water and dry the freezer.
- Release the remaining water.

### **Normal operating sounds you may hear**

- You may hear a boiling, rattling or gurgling sound produced by flow of refrigerant through the evaporator.
- You may hear air being forced through the unit by the evaporator fan.
- You may hear air being forced through the condenser by the condenser fan.
- You may hear a clicking sound produced by the refrigerant valve or dispensing valve.
- You may hear a water dripping sound during automatic defrost cycle.

- You may hear a high pitched hum or pulsating sound produced by the compressor.
- You may hear the ice cubes being ejected from the icemaker to the ice bin.

## **INSTALLATION INSTRUCTIONS**

### **Location**

<b>CAUTION</b>	<b>This unit is designed for indoor use only. Use the rear wheels to move the unit around.</b>
----------------	--

- Place the unit away from direct sunlight and heat sources.
- Do not install the unit in moist areas.
- Do not install the unit in the garage.
- Do not install the unit where the ambient temperature range will be below 50 °F or above 100 °F.
- The unit must be placed in a properly ventilated location. Failure to do so will prevent the unit from cooling properly, and may result in damage to unit components as well as its contents and will void the warranty.
- The unit must be installed on a floor that is level and strong enough to support a fully loaded unit up to 200 lb.

### **Clearance**

<b>CAUTION</b>	<b>This unit is designed for free-standing installation only.</b>
----------------	---

- Allow for minimum 2" on the back, 4" clearance on each side, and 12" at the top for proper air circulation.
- If the unit is installed next to a fixed wall on the right side, leave 6" minimum clearance to allow the door to swing.
- Adjust the leveling legs to level the unit at a height that allows the door to be opened and closed properly.

### **Electrical Requirements**

<b>DANGER</b>	<b>It is required that you connect this unit only to a GFCI protected receptacle. Using an adapter or an extension cord to connect this unit will void the warranty.</b>
---------------	--

- A dedicated 115V, 60Hz, 15 amp fused & grounded electrical supply is required. It is recommended that a separate circuit serving only your appliance be provided.
- Connect to properly grounded outlets only.
- Use outlets that aren't controlled by a switch.

- Plug the unit into a grounded 3 prong outlet only.

### How to insert or disconnect a tube or plug

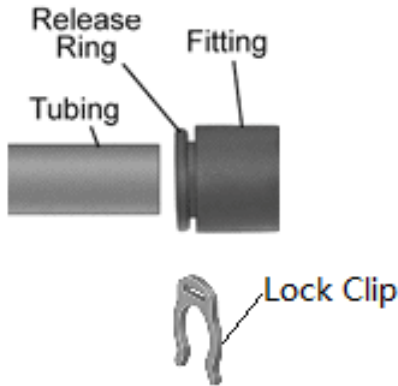

1. Remove the lock clip first.
2. To install, insert a tube or plug until it is engaged;  
To disconnect, press the release ring down and pull out a tube or plug.
3. Install the lock clip.

### If Using Bottled Water

<b>NOTE</b>	<b>Use a 3, 4 or 5 gallon bottle of purified water only. A drain is not required.</b>
-------------	---

#### Bottle adapter and water bottle installation

- 1 Bottle Adaptor connection
- 2 Water inlet
- 3 Water outlet
- 4 Water release drain
- 5 Water Selection Switch
- 6 Filter mounting holes
- 7 Filter mounting bracket
- 8 R/O drain fitting

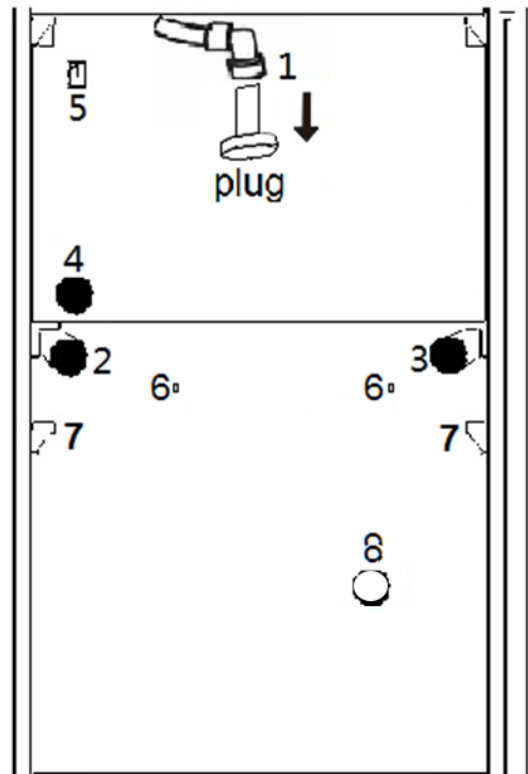

- Open the storage door more than 90 degrees.
- Check that the water inlet (2) and outlet (3) are connected using a loop of ¼" OD tubing. If the tubing is not present, these connections must be plugged.
- Clean the outside of new bottle with a clean cloth. Remove bottle cap completely from the top of the bottle.
- Un-package and assemble the Bottle Adaptor assembly.
- Place the bottle adaptor probe into the bottle.
- Slide the bottle adaptor over the neck of the bottle and push down to secure.
- Push probe down until the tube hits the bottom of bottle.



- Connect the pump pipe to the bottle adapter by inserting the blue elbow fitting into the white collet, pushing in until secure.
- Slide bottle into cabinet and close the door.
- Turn the water selection switch (5) as indicated to use bottled water
- Plug in the unit to restart.

### If Using POU or Filtered Water Supply

<b>Warning</b>	<b>Do not use with water that is microbiologically unsafe or of unknown quality without adequate disinfection before the system.</b>
----------------	--

<b>Warning</b>	<b>This dispenser is designed to work with a water pressure between 15 and 100 psi. A pressure regulator must be used for all installations. This will help prevent internal structural damage to the unit and potential water leaks. The pressure regulator should be installed on the water supply before the inlet connection</b>
----------------	--

- Remove the plug from the inlet water supply bulkhead fitting (8), which is located on the back of the unit. Insert the free end of the water supply tubing into the fitting (8) until it is engaged.

## Water filter installation

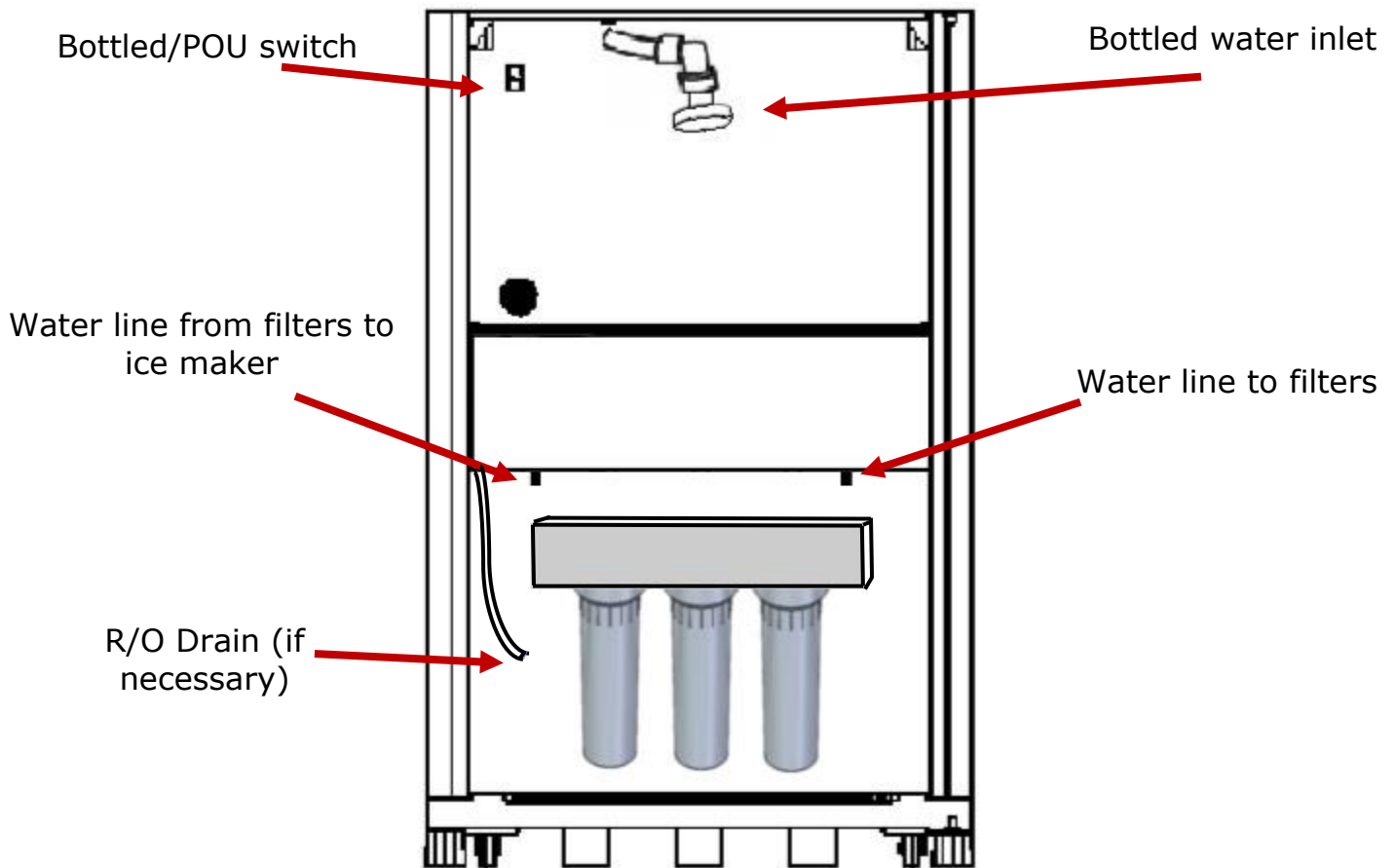

### Note

**A filtration installation is shown. Reverse Osmosis systems may require additional plumbing.**

- Open the storage door more than 90 degrees.
- Check if the pump pipe connector (1) is closed with a plug.
- Install your filtration package inside the bottom, internal recessed area using the bracket provided or by attaching the appropriate mounting brackets for your system to the rear wall. The unit comes pre-drilled to meet standard configurations. **TAKE CARE NOT TO DRILL OR SCREW INTO THE TOP OR SIDES AS IT MAY DAMAGE THE UNIT.**
- If installing a Reverse Osmosis system, there is a bulkhead fitting provided for the drain connection.
- Before connecting the filter kit to the icemaker inlet, make sure to flush the filter system according to the manufacturer's instructions.
- If not installing filtration or if feeding the unit with previously treated water, run a 1/4 OD water line from the inlet fitting on the left to the ice maker inlet fitting on the right.
- Turn the shutoff valve on and make sure there are no water leaks.
- Turn the water selection switch (5) as indicated to use Regular Filter or RO Filter.
- Plug in the unit to reset/restart.

# TROUBLESHOOTING

Complaint	Possible Causes	Response
<b>Unit is not working and display is not lit</b>	<ul style="list-style-type: none"> <li>a. Power cord is unplugged.</li> <li>b. No power at outlet.</li> <li>c. Power cord is broken.</li> <li>d. Control PCB is defective or has wiring problems.</li> <li>e. Display PCB is defective or has wiring problems.</li> </ul>	<ul style="list-style-type: none"> <li>a. Plug in the power cord.</li> <li>b. Check outlet and breaker or fuse.</li> <li>c. Call for service.</li> <li>d. Call for service.</li> <li>e. Call for service.</li> </ul>
<b>“Low” indicator appears (internal water reservoir is at low water level, to reactivate the water pump or inlet valve, press and hold “Light/Reset” button for more than 3 seconds)</b>	<ul style="list-style-type: none"> <li>a. The water selection switch is not set correctly.</li> <li>b. Water bottle is empty.</li> <li>c. Plumbed water supply is turned off or line is broken.</li> <li>d. Air is trapped.</li> <li>e. Internal water tubes are loose, kinked or broken.</li> <li>f. The water pump is defective or has wiring problems</li> <li>g. The water inlet valve is defective or has wiring problems.</li> </ul>	<ul style="list-style-type: none"> <li>a. Select bottled or plumbed water source, then unplug and plug the unit.</li> <li>b. Replace it.</li> <li>c. Fix it.</li> <li>d. Release cups of water from the water release drain.</li> <li>e. Call for service.</li> <li>f. Call for service.</li> <li>g. Call for service.</li> </ul>
<b>Icemaker is not producing ice</b>	<ul style="list-style-type: none"> <li>a. Water level is low and “Low” indicator appears.</li> <li>b. There is ice in the ice mold, but the icemaker is turned off.</li> <li>c. There is ice in the ice mold, but ice cubes are jammed.</li> <li>d. There is no water in the ice mold and the water fill tube freezes.</li> <li>e. There is no water in the ice mold and the water filters are clogged.</li> <li>f. There is no water in the ice mold and the icemaker water pump is defective or has wiring problems.</li> <li>g. There is ice in the ice mold, but the icemaker is not working.</li> <li>h. There is water in the ice mold but the cooling system is not working.</li> </ul>	<ul style="list-style-type: none"> <li><b>a. See “Low” indicator appears.</b></li> <li>b. Turn the icemaker on.</li> <li>c. Clear the ice cubes.</li> <li>d. Unplug the unit and remove the ice bin then wait until fill tube is clear.</li> <li>e. Replace the water filters and check if ice quality improves.</li> <li>f. Call for service.</li> <li>g. Call for service.</li> <li>h. Call for service.</li> </ul>
<b>Icemaker is not producing enough ice or ice cubes are small</b>	<ul style="list-style-type: none"> <li>a. The freezer door is not closed properly.</li> <li>b. The ice chute flap is not closed properly</li> <li>c. Air is trapped in the icemaker water line and the ice mold is not filled with sufficient water.</li> <li>d. The icemaker water pump is not working properly.</li> <li>e. The icemaker is not working properly.</li> </ul>	<ul style="list-style-type: none"> <li>a. Check for the door seal and door opening.</li> <li>b. Check for the flap.</li> <li>c. Release several cups of water from the water release drain.</li> <li>d. Call for services.</li> <li>e. Call for service.</li> </ul>

	f. The cooling system is not working properly.	f. Call for service.
<b>Ice cubes are hollow</b>	a. The icemaker thermostat is defective. b. The icemaker water pump is defective.	a. Call for service. b. Call for service.
<b>Ice cubes are frozen together in the ice bin</b>	a. If ice cubes haven't been used for a long period of time, they may freeze together. b. Ice cubes are produced continuously because the feeler arm is blocked up. c. The freezer door is not closed properly. d. The icemaker is not working properly. e. The cooling system is not working properly.	a. Pull out the ice bin and shake it or remove the large clumps of ice cubes. b. Clear ice cubes around the feeler arm. c. Check for the door seal or door opening. d. Call for service. e. Call for service.
<b>Crushed ice is not dispensed</b>	a. There are not enough ice cubes in the ice bin. b. Ice cubes are frozen together in the ice bin. c. The freezer door is open. d. The freezer door magnetic switch is defective. e. The auger motor is broken. f. The flap motor is broken or has wiring problems. g. Control PCB is defective or has wiring problems. h. Display PCB is defective or has wiring problems.	a. See <b>Icemaker is not producing ice or Icemaker is not producing enough ice or ice cubes are small.</b> b. Pull out the ice bin and shake it or remove the large clumps of ice cubes. c. Close it. d. Replace it. e. Call for service. f. Call for service. g. Call for service. h. Call for service.
<b>Cubed ice is not dispensed</b>	a. There are same problems as crushed ice. b. The solenoid is defective.	a. See <b>Crushed ice is not dispensed.</b> b. Call for service.
<b>Hot water is not hot</b>	a. The water heater stops working automatically when "Low" indicator appears. b. The hot water function is turned off. c. The water heater is broken. d. The thermostat is defective.	a. See <b>"Low" indicator appears.</b> b. Turn the hot water function on. c. Call for service. d. Call for service.
<b>Hot water is not hot enough</b>	a. The thermostat is defective.	a. Call for service.
<b>Hot water heater smells "hot"</b>	a. The hot water tank is dry boiling.	a. Call for service.
<b>Water dispensing is not working</b>	a. The water dispensing valve stops working automatically when "Low" indicator appears. b. Air is trapped. c. The dispensing valve water tubes are broken. d. The water dispensing valve is defective. e. Control PCB is defective or has wiring problems.	a. See <b>"Low" indicator appears.</b> b. Release cups of water from the water release drain. c. Call service. d. Call service. e. Call service. f. Call for service.

	f. Display PCB is defective or has wiring problems.	
<b>Water dispenser is slow</b>	a. The water dispensing tubes are kinked. b. The water dispensing valve is defective.	a. Straighten them. b. Call service.
<b>Water is leaking</b>	a. The dispenser drip tray is full. b. The condensate drip tray is full. c. The internal water reservoir or tubes is leaking. d. The internal water reservoir water level sensor is defective. e. The water dispensing valve is defective. f. Ice is being melted because of high freezer temperature.	a. Empty it. b. Empty it. c. .Call for service. d. Call for service. e. Call for service. f. Check for power or call for service.
<b>Icemaker evaporator is iced</b>	a. The freezer door is not closed properly. b. The ice chute flap is not closed properly. c. Water fill tube is leaking water.	a. Close it. b. Close it. c. Align the fill tube in the fill cup.
<b>Both freezer and icemaker evaporators are iced</b>	a. The defrost solenoid valve is defective or has wiring problems. b. The defrost drip tray heater is broken or has wiring problems. c. The evaporator fan is broken. d. The defrost sensor is defective. e. The freezer sensor is defective.	a. Call for service. b. Call for service. c. Call for service. d. Call for service. e. Call for service.

## Codes

<b>Codes</b>	<b>Faults</b>	<b>Response</b>
<b>E01</b>	Defrost temperature probe is defective	Call Service
<b>E02</b>	Freezer temperature probe is defective	Call Service
<b>E03</b>	Hot water temperature probe is defective	Turn off "Hot" & Call Service
<b>E04</b>	Hot water temperature is extremely high	Turn off "Hot" & Call Service
<b>E05</b>	Water level float switch is defective	Turn off "Hot" & Call Service
<b>E06</b>	Freezer door is open	Close Door
<b>E07</b>	Icemaker is not functioning properly	Call Service
<b>E08</b>	Display Board or Control Board	Call Service
<b>E09</b>	Freezer temperature is extremely high	Disconnect Power and Call Service
<b>E10</b>	Freezer temperature is high	Disconnect Power and Call Service

## SERVICE & WARRANTY NOTICE

The manufacturer has a policy of continuous improvement on its products and reserves the right to change materials and specifications without notice.

Vertex Water Products 5138 Brooks Street Montclair, California 91763  
800-627-2146 www.vertexwater.com email: inquiries@vertexwater.com

### Two Year Limited Warranty

#### **GENERAL PROVISIONS AND EXCLUSIONS:**

This warranty is only applicable in North America including: United States of America, Canada and Mexico.

This warranty is void if the data plate is removed or the serial number is not legible.

This warranty is void if original Vertex Water Products parts are not used to repair the water cooler. Service to the sealed refrigeration system must be performed by an authorized Vertex service agent or Vertex. This warranty does not cover damage or parts that fail as a result of hardness or scale build up from water conditions.

This warranty does not cover to any water cooler or components that become inoperable because of a failure to comply with any local, state, regional, federal or other standards or regulations.

Vertex Water Products is not liable for damages or wear to products caused by abnormal usage, application, misuse, unauthorized modification or repair, or if the products were not installed in accordance with Vertex Water Products' installation and operating instructions, or for any damage caused by, freezing, flood, fire, or acts of God.

#### **YEAR ONE and TWO:**

Vertex Water Products Inc. promises the original purchaser (user) to repair, or replace, at Vertex's discretion, any part of the sealed refrigeration system which is determined by Vertex to be defective in material or workmanship within the first two years from the date of original purchase. Vertex will provide parts necessary to repair the product at no charge, provided that the water cooler has been installed and operated according to the manufacturer's written instructions. Failure to follow all instructions for operation and maintenance provided with this unit voids the warranty.

Vertex will within the first year from the date of original purchase, repair or replace, at Vertex Water Product's discretion, any component part which is determined by Vertex to be defective in material or workmanship.

If it becomes necessary to ship the defective water cooler to the approved service center or to Vertex, the user will be responsible for shipping the defective product, prepaid. Local pick-up and delivery charges are not covered.

The warranty does not cover charges to disconnect and reconnect plumbing and electrical connections. In addition, the warranty does not cover the cost of diagnosing a problem with the sealed refrigeration system

#### **DISCLAIMER:**

Vertex Water Products hereby disclaims any and all implied warranties including, but not limited to, the implied warranties of merchantability and fitness for a particular purpose. The manufacturer or its agents shall not be liable for consequential damages, whether economic or otherwise, resulting from breach of this limited warranty. Failure to follow all instructions for operation and maintenance provided with this unit voids the warranty.

The foregoing is in lieu of all other agreements expressed, implied or statutory and all other obligations or liabilities of Vertex. Vertex does not assume or authorize any person to assume any obligations of liability in connection with this product. In no event will Vertex be liable for special or consequential damages or for any delay in the performance of this agreement due to causes beyond their control.

Copyright © 2018 Vertex Water Products Inc. All rights reserved.