

PureWaterCooler

PureChill Water Dispenser

OWNERS INSTALLATION MANUAL

PWC-9500



VERTEX WATER PRODUCTS

Table of Contents

	Page
1.0 Introduction	1
2.0 Receiving	1
3.0 Product Description	2
4.0 Installation	5
5.0 Operation	9
6.0 Filter Monitor	11
7.0 Filter Replacement	12
8.0 Leak Detection	13
9.0 Trouble Shooting Guide	15
9.0 Specifications	16
10 Warranty	17

List of Figures

Fig. 1 Flow Schematic	2
Fig. 2 PWC-9500 Assembly	3
Fig. 3 Back View of Cooler	4
Fig. 4a-b Installation Precaution	5-6
Fig. 5 Saddle Valve	7
Fig. 6 Quick Connect Fittings	8
Fig. 7 Hot/Cold Power switches	9
Fig. 8 Control Panel	10
Fig. 9 Tank Drain	11
Fig. 10 Leak Detection	13
Fig. 11 Leak Detection probes	14

1.0 Introduction

The Vertex **PureWaterCooler™** products are a means to produce good-tasting, safe water without using bottles of stored water. The **PureChill** model PWC-9500 described here is made for floor-standing use.

Please read all the instructions in this manual before operating the **PureWater-Cooler™**.

2.0 Receiving the Cooler

2.1 Unpacking

The **PureChill™** model PWC-9500 is shipped completely assembled in 2 separate cartons. Open the top assembly box and pull the cooler out. Save the box and packing materials for use in the event of a return. The cooler base cabinet is shipped separately in another carton. Remove the top of the box and pull the cabinet off of the base of the carton.

2.2 Inspection

Inspect the cooler top assembly and base cabinet for obvious shipping damage. Look at the exterior panels to see if they are dented or damaged.

3.0 Description

3.1 Assembly

The countertop portion of the PWC-9500 assembly drawing is shown in Figure 1. The cooler has one chilling chamber and one hot tank. This chilling chamber holds one gallon of water and is automatically filled at start-up. This water is cooled in the chilling chamber with refrigerant coils. The cold water drinking line is comprised of a sealed stainless steel coil submerged inside this chamber. There is a separate hot water tank with an internal heater coil which is fed by water pressure directly from the line in. The hot water tank is directly beside the cold water tank. The compressor and expansion valve are inside the cabinet. The controls for dispensing water are on the front panel.

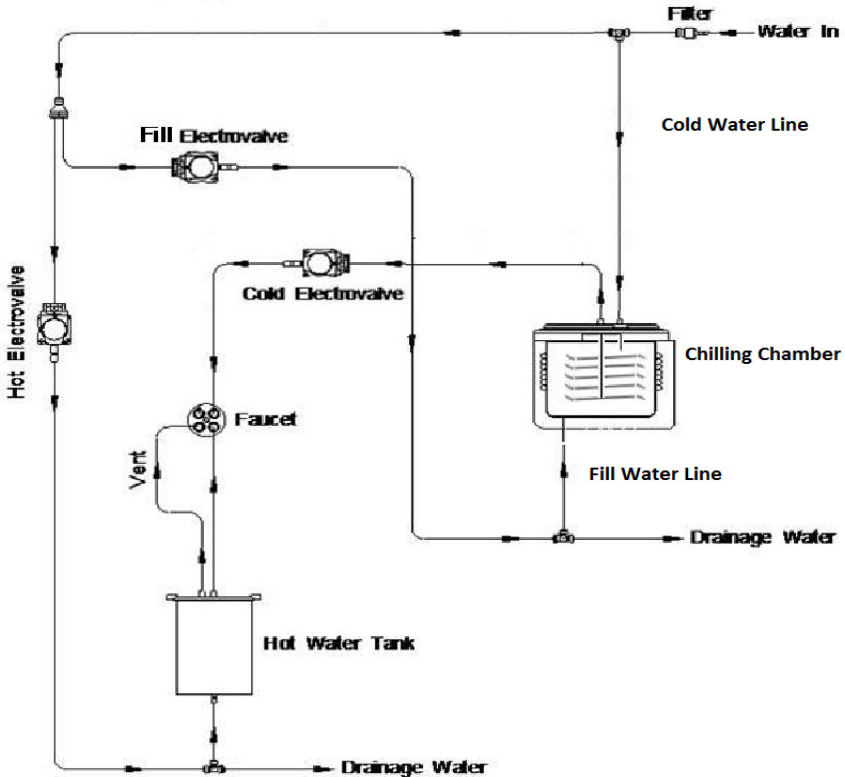

Figure 1 Flow Schematic

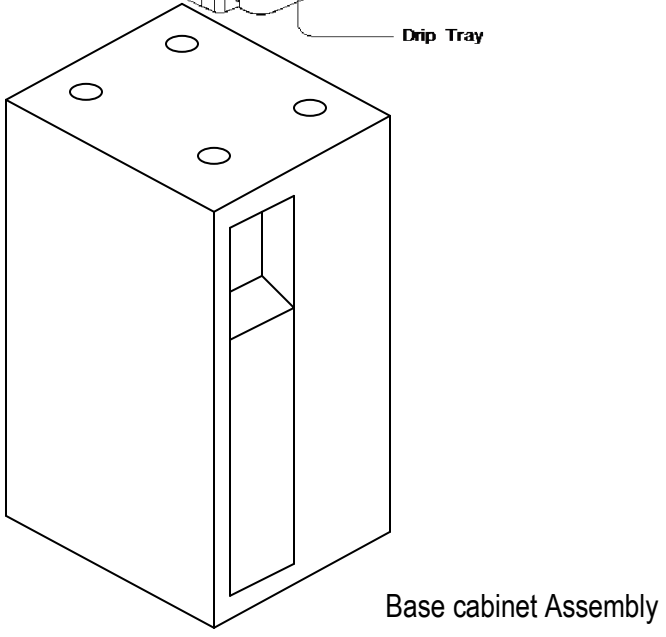
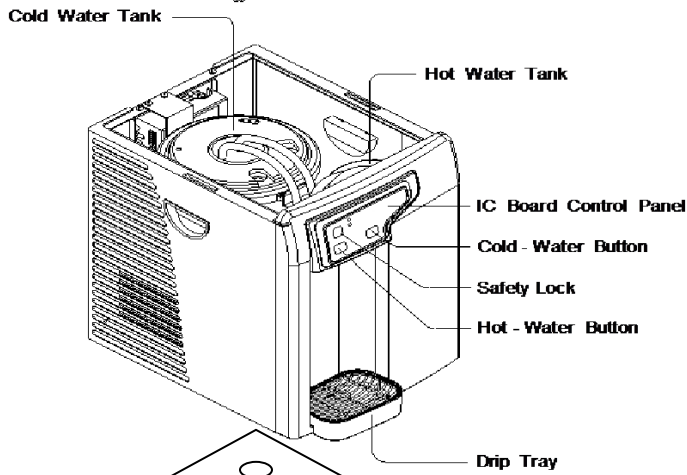
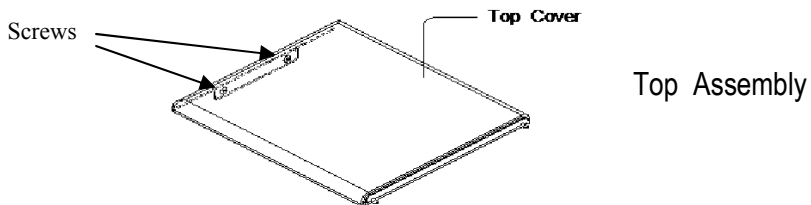

Figure 2 PWC-9500 Assembly

3.2 Rear View

On the back of the cooler are the main power switches; one for heating and one for cooling. When heating or cooling is occurring, indicator lights on the front panel will turn on. The hot temperature is fixed at a nominal 180°F and is controlled with a thermostat mounted on the outside of the hot tank. The cold temperature can be adjusted between 36°F and 54°F by using a screw driver on the slot on the back. Turn to the left to increase warmth and to the right to increase cold. DO NOT TURN PAST THE STOPS. There is a cooling fan which exhausts to the rear, so a clearance of 6-inches from a wall is required.

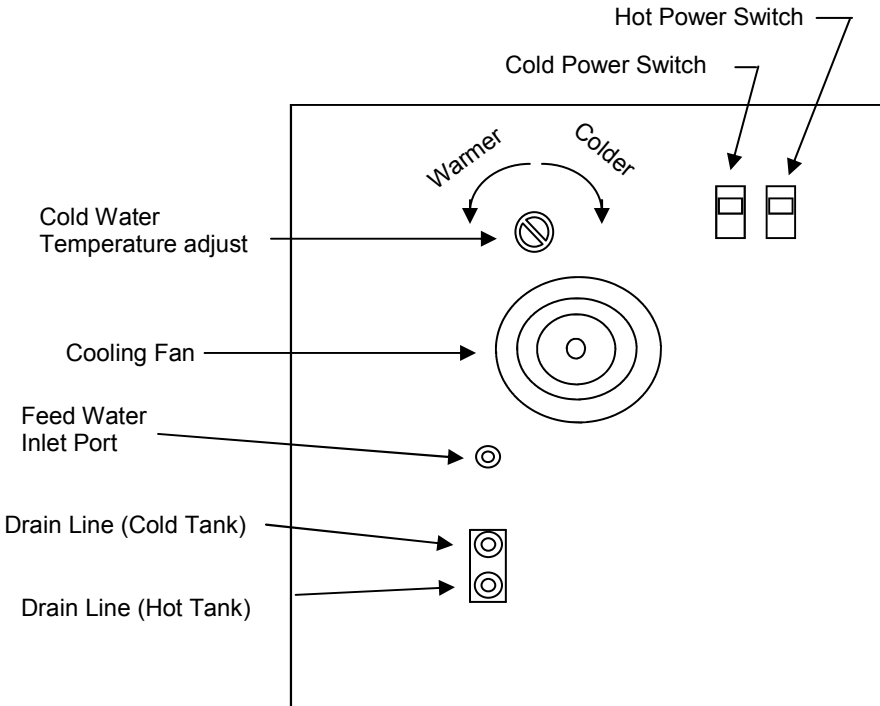

Figure 3 Back View of Cooler

4.0 Installation

4.1 Assembly of Countertop to Cabinet

Identify the four depressions on the top of the base cabinet where the four feet of the cooler will locate. Lift the cooler and placed it on top of the cabinet, aligning the feet of the cooler to the previously located depressions.

4.2 Positioning the Cooler

There are some precautions to take when positioning and using the **PureWaterCooler™**. See the items in Figure 4a and 4b. In addition, the cooler must be located near the supply water. Flexible 1/4-inch plastic tubing may be used for the feed connection. Normally, this connection should be within 25-feet of the cooler.

Important Note: Do not cover air intake vent as this will prevent proper chilling from occurring.

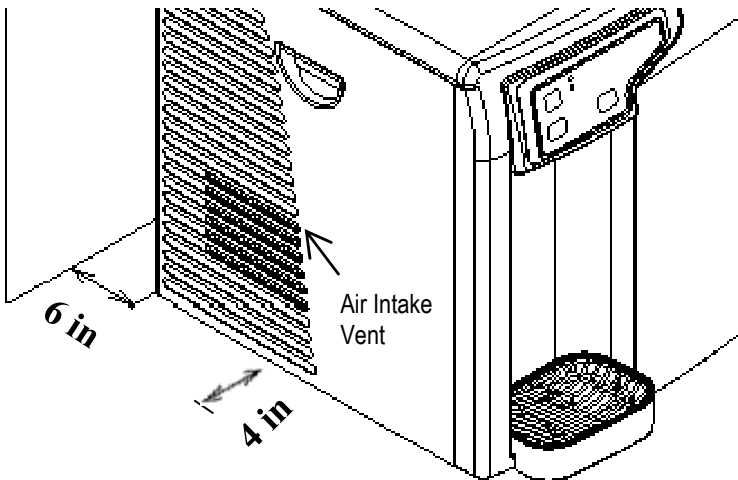

Keep at least a 6 in. distance between the cooler and the wall.

Figure 4a Installation Precautions

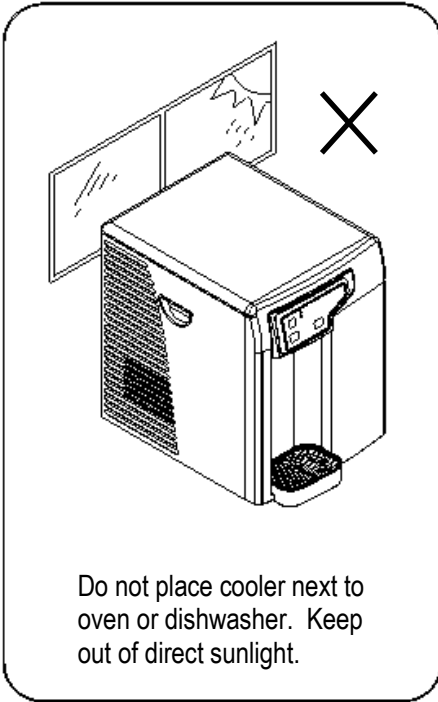

Do not place cooler next to oven or dishwasher. Keep out of direct sunlight.

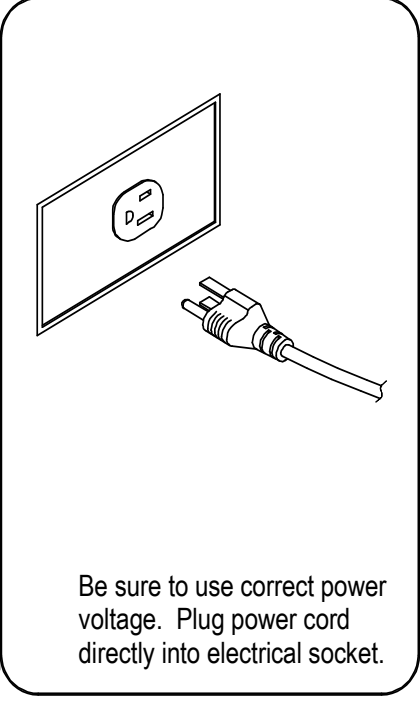

Be sure to use correct power voltage. Plug power cord directly into electrical socket.

Figure 4b Installation Precautions

4.3 Cooler Water Connections

When received, the water connections on the back of both the cooler and the cabinet have color coded tube sections with red shipping caps on them. These tube sections must be removed before making water connections. To remove the tube sections see Figure 7. The 1/4" plastic tubing should be used for making the Feed Water. If hard copper tubing is used for the Feed Water and Drain connections, the bulkhead fittings must be changed to a metal fitting.

4.4 Feed Water Connections

To connect the feed water, use the supplied self-piercing saddle valve to connect to the cold water supply line under the sink. Attach the 1/4" tubing to the compression fitting on the side of the valve. Clamp the saddle valve over the copper or plastic feed line (cold water only). Turn the handle on the valve until the needle stem pierces the tube. Then retract the needle 1-2 turns to start water flow. See Figure 5.

If the cabinet has a filtration system installed, connect the feed water tubing to the lower bulkhead located on the rear of the cabinet. Plumb from the upper bulkhead on the cabinet to the feed water bulkhead on the rear of the cooler using the supplied stem elbow and tubing assembly.

If the cabinet does not have a filtration system installed, simply connect the feed water to the bulkhead on the rear of the cooler.

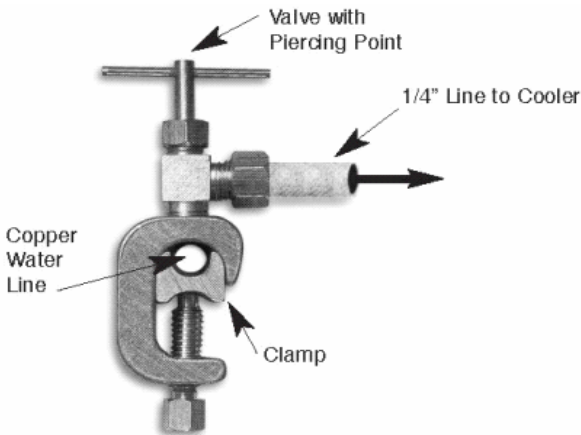
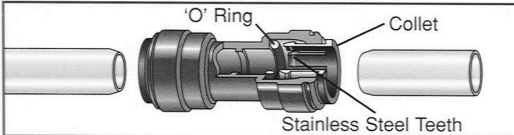

Figure 5 Saddle Valve

4.5 Quick Connect Fittings

The standard tubing connections on the **PureWaterCooler™** are of Quick Connect O-ring seal design and manufacture. Use the tubing and follow the instructions below to make the connections. If you cut the tubing make sure it is a square cut, fits squarely in the fitting, and seals properly.

1 Cut tube square



Cut the tube square. It is essential that the outside diameter be free of score marks and that burrs and sharp edges be removed before inserting into fitting.

2 Insert tube

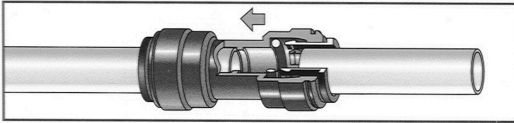

Fitting grips before it seals. Ensure tube is pushed in to the tube stop.

3 Push up to tube stop

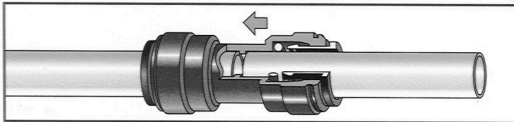

Push the tube into the fitting, to the tube stop. The collet (gripper) has stainless steel teeth which hold the tube firmly in position while the 'O' ring provides a permanent leak proof seal.

4 Pull to check secure

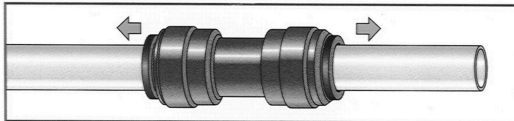

Pull on the tube to check it is secure. It is good practice to test the system prior to leaving site and/or before use.

Disconnecting

Push in collet and remove tube

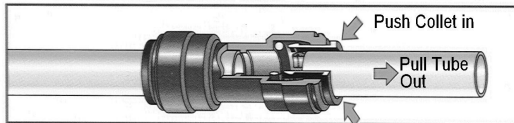

To disconnect ensure the system is depressurized before removing fitting. Push in collet squarely against face of fitting. With the collet held in this position, the tube can be removed. The fitting can then be re-used.

Figure 6 Quick Connect Fittings

5.0 Operation

5.1 Start Up

- a. Connect feed water line and all tubing according to instructions. If cabinet does not have filtration system installed, skip to step e. Open door of cabinet to expose filtration system. Turn the water on at the piercing valve or feed water valve.
- b. From the inside of the cabinet, disconnect the tubing from the upper bulk-head and flush water through filtration system into a pan or bucket by opening the feed water ball valve.
- c. Once water runs clear, close ball valve and reconnect tubing to upper bulk-head.
- d. For filtration configured coolers, open feed water ball valve. For non-filtration coolers, turn water on at the piercing valve.
- e. Make sure Cold and Hot power switches at back of cooler are OFF before plugging the cooler into 110-volt wall socket. (See Figure 7a)

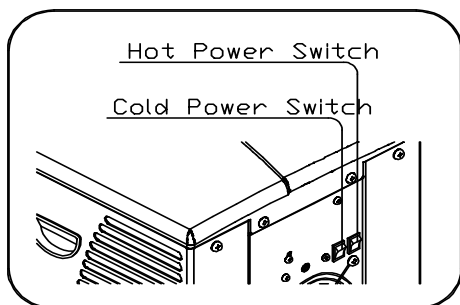

Figure 7 Hot/Cold Power Switches

- f. Plug in power cord. Cooling chamber fill valve will automatically open (with audible click) allowing water to fill cooling chamber until full (30-60 seconds for no filter and 'F' configurations). Valve will then close automatically. NOTE: The chilling chamber has a re-circulation pump that will come on automatically when plugged in. The pump may make noise if the tank has not yet filled with water.
- g. To dispense cold water press Cold dispense button & hold until water dispenses in a full stream (about 5-10 seconds). Water will now dispense on demand.
- h. To fill hot tank with water, first press and hold the lock button on the front panel of the cooler. A beep sound will be heard after 1 second indicating that the hot button has been unlocked. Next, press and hold (within 5 seconds of beep sound) the hot water dispense button until water starts dispensing from spigot (about 1 minute) Water will now dispense on demand.

- i. **System Flush:** It is recommended to flush both the cold and hot systems by dispensing 16-32 ounces of water out of each at Initial start-up. First press and hold the cold dispense button until 16-32 oz have been dispensed. Then press hot lock until beep and then press and hold hot dispense button until 16-32 oz of water have been dispensed. The system is now ready to operate.
- j. Turn on hot and cold switches on the back of the cooler. Heating and cooling will start.
- k. The temperature of cold water is set at the factory. Using a flat screw driver, the temperature can be adjusted, if needed, by turning the temperature control slot Clockwise for colder and Counterclockwise for warmer (See Figure 3).

CAUTION: If you turn the COLD POWER button off, wait at least 3 minutes before turning on again to protect the compressor from damage.

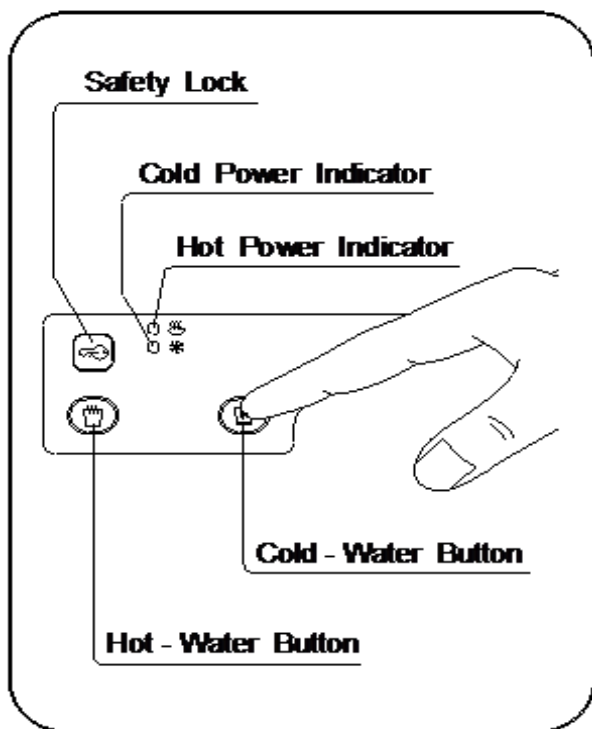

Figure 8 Control Panel

5.2 Tank Drain

Occasionally, it may be desirable to drain both tanks, the hot tank and chilling chamber. There are drain plugs on the back of the cooler. See Figure 8. First, make sure all power is off. The cooler must be moved so that the water can be drained into a container to collect the water (about 1 1/4 gal). Remove the cover on top of the hot and cold water drain.

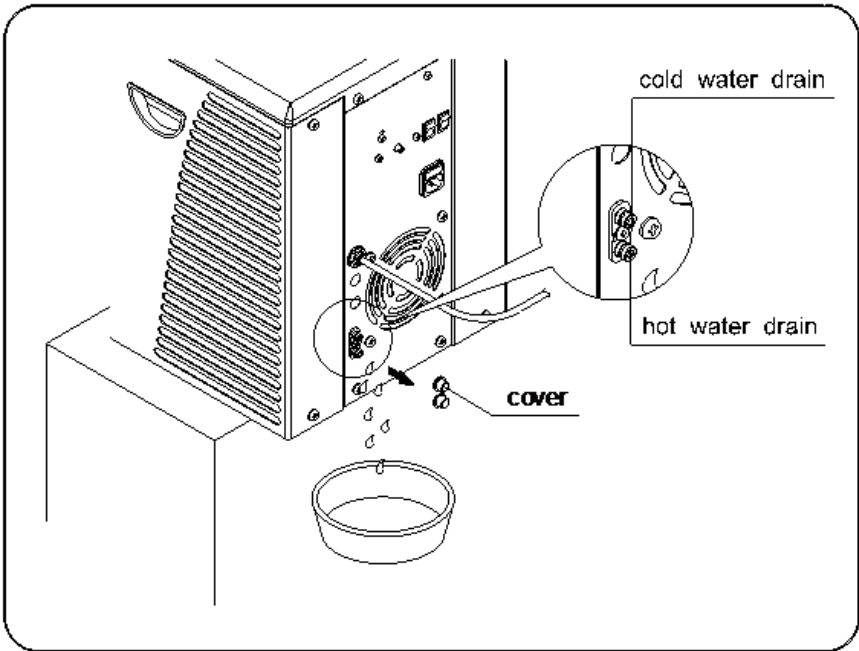

Figure 9 Tank Drain

6.0 Filter Monitor Operation

When water is dispensed, the green indicator light will blink. When the indicator light starts to blink yellow, this indicates that 90% of the filter life has been used and that the filters should be changed soon.

When the filters are changed, reset the filter monitor by removing and replacing the battery. The filter monitor sensor and battery is located in the filter compartment. The watch style battery is partially exposed and can be removed by pulling on the battery with finger nails or pliers. Battery should be replaced every year or 2nd filter change, whichever is first.

7.0 Filter Replacement

The filter elements must be replaced at regular intervals to maintain the quality of the water.

The “F” Model 9500F has 2-stages of mechanical filtration, the “R” model 9500R has 2-stages of mechanical filtration plus additional RO membrane. The filters are accessed through the lower front door panel. A 1st stage 5-micron sediment filter and a 2nd stage activated carbon filter. Both stages 1 & 2 must be replaced every 6-12 months. For the “R” version the RO membrane (stage 3) is replaced every 2-3 years.

7.1 Sediment and Carbon Filter Replacement Procedure

- a. Unplug the cooler from the wall socket.
- b. Access the filter compartment by opening lower door panel
- c. Close Service ball valve (blue handle) by turning valve handle perpendicular to flow tubing.
- d. To remove the sediment and carbon filter cartridge, rotate the filter cartridge 1/4 turn counter clock -wise and pull down.
- e. Install a new carbon and sediment filter in the indicated positions.

Use these replacement filters for PWC 9500F

1st stage Sediment filter, P/N TF-4113

2nd stage Carbon Block filter, P/N TF-4115

- g. Plug in the power cord. Press cold dispense button and Let water run until it is clear.

7.2 RO membrane Replacement

With the cooler unplugged and the filter compartment open, disconnect the 3 tubes of the RO filter housing. (see sect. 4.5 Quick Connect Fittings) Remove the RO housing from the filter clips. Remove the cap from the housing by unscrewing it.

Using a pair of pliers, remove the RO element from the housing by grasping the tube end and pulling it out. Use RO filter replacement P/N ma-4205 (100gpd TFC membrane). Insert the element into the housing with the double “o”-ring end going in first, toward the bottom of the housing. Make sure the “o”-rings are seated. Replace the cap. Reconnect the tubing and replace housing in filter clips. Replace cover and plug in cooler. Flush 2 gallons of clean water out of membrane before drinking to remove preservative in the RO membrane.

8.0 Leak Detection System

There are 2 leak detection systems installed in the cooler, one is mechanical, mounted in the lower cabinet in the rear of the filter compartment ; the other is electronic and mounted on the LHS rear of dispensing unit. (see diag.11)

If water leaks to the base of the cooler cabinet, the mechanical leak detector valve will close and shut off the feed water to the filters and the cooler.

To access the mechanical leak valve open front door of lower cabinet and locate the leak valve near the rear of the cabinet RHS.

- Remove any excess water in the bottom compartment
- Reset the leak valve by replacing expanded activation cartridge with New cartridge (a spare activation sponge is supplied with the cooler)
- Reset leak valve to open/ON position by pressing lever down (see Figure 10)

NOTE: It is not necessary to remove the plastic wrapping from the replacement cartridge– install with bevel side down.

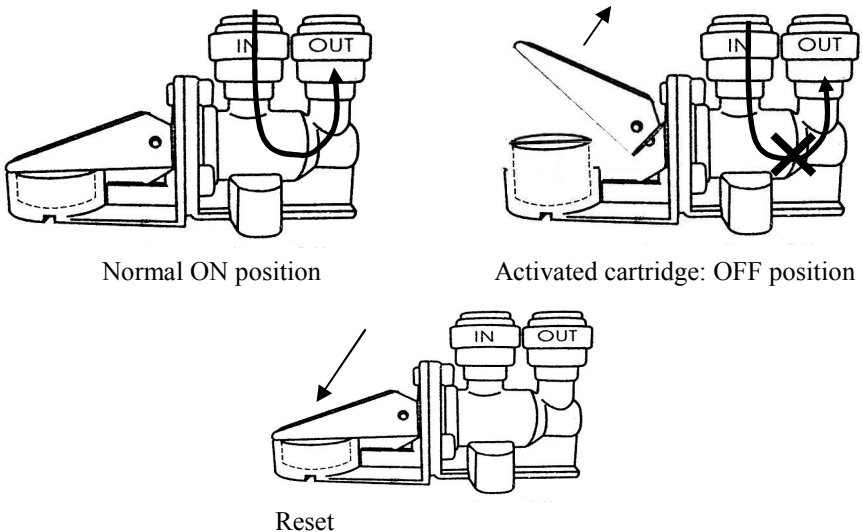

Figure 10 Leak Detector mechanical valve diagram

8.1 Electronic Leak Detection system

The electronic water leak detection system is installed in the rear left had corner of the cooler. If a water leak should occur inside the cooler and water collects in the leak probe tray the power will automatically be shut off.

When power is cut off due to water leak:

- a. Un-plug the cooler and remove the left side panel by removing the 2 screws and sliding the panel back .
- b. Remove any excess water in the bottom, lift and wipe the detection probes dry. Replace all removed components.
- c. Re-connect power to reset the leak controller in the unit and check for leaks.

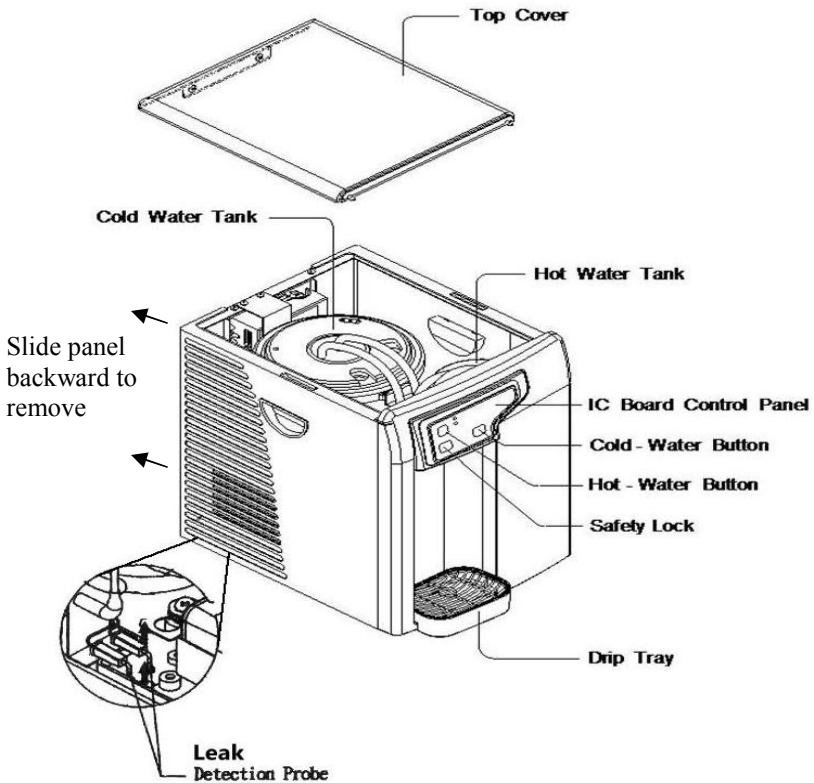

Figure 11 Leak Detector Electronic probes

9.0 Trouble Shooting Guide

Problem	Cause	Solution
Panel Not Lit	No Power	<ul style="list-style-type: none"> • Check that power cord is plugged in. • Confirm that no water is at leak probes.
Will Not Cool	Controls Not Set Thermostat in rear	<ul style="list-style-type: none"> • Turn on cold power switch on back • Turn to right about 1/2 turn for colder water
Cold Water is Not Cold Enough	Unit is too close to wall so cooling fan isn't effective Refrigerant has leaked	<ul style="list-style-type: none"> • Move unit 6 inches away from wall • Make sure intake vent is not blocked • Contact dealer
No Hot Water	No Power Temperature control sensor faulty	<ul style="list-style-type: none"> • First, check that front "Hot" light is lit. If not, turn hot power switch on back. • Thermostatic controller on hot tank may not be functioning. • Check with dealer.
Unit Shut Off Panel Not Lit	No Power	<ul style="list-style-type: none"> • Check that power plug is in. • Check hot/cold power switch is on. • Confirm that no water is at leak probes.
Water Won't Come Out of Spigot	No Power	<ul style="list-style-type: none"> • Check that power cord is plugged in.

8.0 Specifications

Model No.	PWC-9500
Voltage/Frequency	AC110V
Dimensions	13"W x 16"D x 51.5"H
Weight (empty)	81 lb.
Hot Water Tank Capacity	.5 gal.
Cold Water tank Capacity	NA
Power Consumption	Hot Water: 500W
	Cold Water: 100W
Electric Power Cord Length	6Ft.



Conforms to UL STD.399

11 LIMITED WARRANTY

Vertex Water Products (“Manufacturer”) sell its products through independent retailer dealers (“Dealer”) who re-sell to the end-user customer. In this limited warranty, “Vertex” refers to Vertex Water Products and not to the Dealer.

WHO IS COVERED BY THIS WARRANTY

This limited warranty covers only the first purchaser of the Vertex *PureWaterCooler*™ from a Dealer for use by that purchaser, and is not transferrable. “Consumer Use” means personal residential household use by a consumer or consumers. “Commercial Use” means all other uses, including (but not limited to) use for commercial, income producing purposes and/or when purchased by a business and/or when purchased for use in an office, business, or industrial setting. “Purchaser” means the end-user customer, and not a Vertex re-seller Dealer.

PERIOD OF COVERAGE OF THIS WARRANTY

Manufacturer warrants the complete water cooler (“the unit”) against defects in material and workmanship, subject to the exclusions described below, for a period of ONE YEAR, beginning on the later of either (a) the date of purchase or (b) the date of manufacture as identified by the Vertex unit’s serial number. Manufacturer additionally warrants the compressor for a period of THREE YEARS from the above date. The purchaser must provide the original sales receipt as proof of the date of purchase. If the purchaser is unable to produce the original sales receipt, the Warranty Period commencement date will be determined by Manufacturer, in its sole and absolute discretion, based upon the unit’s serial number. This warranty does not apply if the original serial number affixed by Manufacturer is removed, defaced, altered, obscured, tampered with, or obliterated. If Manufacturer provides a replacement part or parts, or repairs a part or parts, under this limited warranty, then the replacement part(s) or repaired part(s) will be covered under this limited warranty for the time remaining under the original Warranty Period applicable to the part(s) repaired or replaced.

The duration of **ALL OTHER WARRANTIES, INCLUDING ANY AND ALL IMPLIED WARRANTIES, INCLUDING BUT NOT LIMITED TO MERCHANTABILITY AND FITNESS FOR A PARTICULAR PURPOSE, ARE RESTRICTED TO THE TWO-YEAR LIMITED WARRANTY PERIOD.** Some states do not allow limitations on how long an implied warranty lasts, so the above limitation may not apply to purchaser.

WHAT IS COVERED BY THIS WARRANTY

This limited warranty covers defects in materials or workmanship, subject to the exclusions below and for the time period stated above. Manufacturer promises to repair or to replace, at Manufacturer’s sole and absolute discretion, any part of this water cooler that proves to be inoperative due to a defect in material or workmanship under normal use.

WHAT IS NOT COVERED BY THIS WARRANTY

This limited warranty does not extend to and expressly excludes:

- conditions, losses, malfunctions, or damages not resulting from defects in material or workmanship;
- conditions, malfunctions, losses, or damages or the inability to operate the Vertex unit resulting from conditions beyond Manufacturer’s control, including but not limited to failure of the unit or any of its parts due to damage caused by: improper installation; accident; fire; flood; windstorm; acts of God; rodent and/or insect infestation; vandalism; modification; alteration; combination with any other device or machine; abuse and/or misuse of the unit; negligence by purchaser or third parties; any part of the water system that has become fouled due to liming, dirt, unsatisfactory/unsanitary water conditions, corrosion, or faulty plumbing; failure to install, maintain, assemble, mount or place the Vertex unit in accordance with Manufacturer’s instructions and/or local, state, or national plumbing and electrical codes; wear and tear expected to occur in the normal course of use, including but not limited to cosmetic rust, scratches, dents or comparable and reasonably expected losses or damages; exposure to extreme variations in ambient environmental conditions (including but not limited to changes in heat, humidity, moisture, or exposure to sunlight).
- labor for installation or deinstallation of the unit or any of its parts; shipping of the unit or any of its parts to Manufacturer for repair/replacement.

In addition to the above exclusions, this limited warranty does not apply if any of the following conditions of operation are not met: System Pressure 35 - 100 psi, Temperature 40 - 100 degrees F, PH range 4 - 10, Max TDS 1500 PPM Max., Turbidity <1.0NTU, Hardness <20gpg, R version: <3.5 gpg, F version, Iron <0.1 mg/l, Manganese <0.1 mg/l, Hydrogen Sulfid e <0.00 mg/l.

NO OTHER EXPRESS OR IMPLIED WARRANTY APPLIES

This limited warranty is the sole and exclusive warranty provided to the purchaser identified above. No other express warranty, written or verbal, applies. No agent, employee, deal or other person or entity is authorized to alter this limited warranty or make any other warranty on behalf of Manufacturer. The terms of this limited warranty shall not be modified by the Manufacturer, the purchaser/end user, or their respective successors or assigns.

WHAT WE WILL DO TO CORRECT PROBLEMS/ HOW TO GET WARRANTY PARTS

If the Vertex unit does not operate in accordance with the documentation provided to purchaser, or purchaser have questions concerning purchasers' Vertex unit, please contact the Dealer from whom the unit was purchased. If the original Dealer is not available or the purchaser does not know who the Dealer is, please call or email the Manufacturer, Vertex, using the contact information provided below. We will try to find a Dealer in purchaser geographical area to assist purchaser. If a Dealer cannot be conveniently located, the Manufacturer, in its sole and absolute discretion, may offer two (2) options. First, we will attempt to troubleshoot the issue with purchaser over the phone. If the purchaser is comfortable making a repair/ replacing a part, once we understand the problem and its solution, we will send the replacement part(s) for the cooler. **This warranty is for the replacement of part(s) ONLY; it does not cover the cost of labor for either the Dealer or the end user/purchaser.** The second option is that the end user/purchaser may, after notifying Manufacturer and receiving written authorization/approval from Manufacturer to do so, send the unit back to Manufacturer and we will repair it. **The end user purchaser must pay the freight/ shipping costs to return the unit to Manufacturer.** Manufacturer will pay the freight/shipping to return the unit to the end user/purchaser following repair.

If the end user/purchaser contacts the Dealer and the Dealer repairs the unit pursuant to this limited warranty, Manufacturer will provide parts to the Dealer at no charge; labor is not included in this limited warranty. The Dealer may, in his or her sole and absolute discretion, decide to repair the unit on-site or take the unit to a shop to repair.

This limited warranty covers replacement or repair of parts only. Manufacturer will not replace the entire unit if a part can be replaced or repaired to restore the unit to full operational function. On the rare occasion that a unit cannot be restored to full operation by a part or parts, Manufacturer will replace the unit after the end user/purchaser has shipped the unit to Manufacturer and Manufacturer has determined, in its sole and absolute discretion, that the unit cannot be repaired and must be replaced. **The end user/purchaser must pay the freight/ shipping costs to return the unit to Manufacturer.** Manufacturer will pay the freight/shipping to return the unit to the end user/purchaser following repair or will ship a new unit if repair is not possible. If Manufacturer does provide a replacement unit, then the Warranty Period (as specified above) for the replacement unit would begin at the time of its delivery to the end user/purchaser.

LIMITATION OF LIABILITY AND DISCLAIMER OF WARRANTIES

TO THE EXTENT PERMITTED BY LAW, IN NO EVENT SHALL MANUFACTURER BE LIABLE TO PURCHASER OR ANY THRID PARTIES FOR ANY INCIDENTAL, SPECIAL, INDIRECT, OR CONSEQUENTIAL DAMAGES, INCLUDING ANY ECONOMIC LOSS, WHETHER RESULTING FROM NON-PERFORMANCE, USE, MISUSE, OR INABILITY TO USE THE VERTEX UNIT. MANUFACTURER SHALL NOT BE LIABLE FOR DAMAGES CAUSED BY DELAY IN PERFORMANCE AND IN NO EVENT, REGARDLESS OF THE FORM OF THE CLAIM OR CAUSE OF ACTION (WHETHER BASED IN CONTRACT, WARRANTY, TORT, INFRINGEMENT, NEGLIGENCE, STRICT LIABILITY, OTHER TORT OR ANY OTHER LEGAL THEORY) SHALL MANUFACTURER'S ENTIRE LIABILITY EXCEED THE PRICE PAID BY THE ORIGINAL PURCHASER FOR THE VERTEX UNIT. THE TERM "CONSEQUENTIAL DAMAGES" SHALL INCLUDE, BUT NOT BE LIMITED TO, LOSS OF ANTICIPATED PROFITS, BUSINESS INTERRUPTION, LOSS OF USE OR REVENUE, COST OF CAPITAL, OR LOSS OR DAMAGE TO PROPERTY OR EQUIPMENT.

Contact information:

Vertex Water Products 5138 Brooks Street Montclair, California 91763
800-627-2146 www.vertexwater.com email: inquiries@vertexwater.com

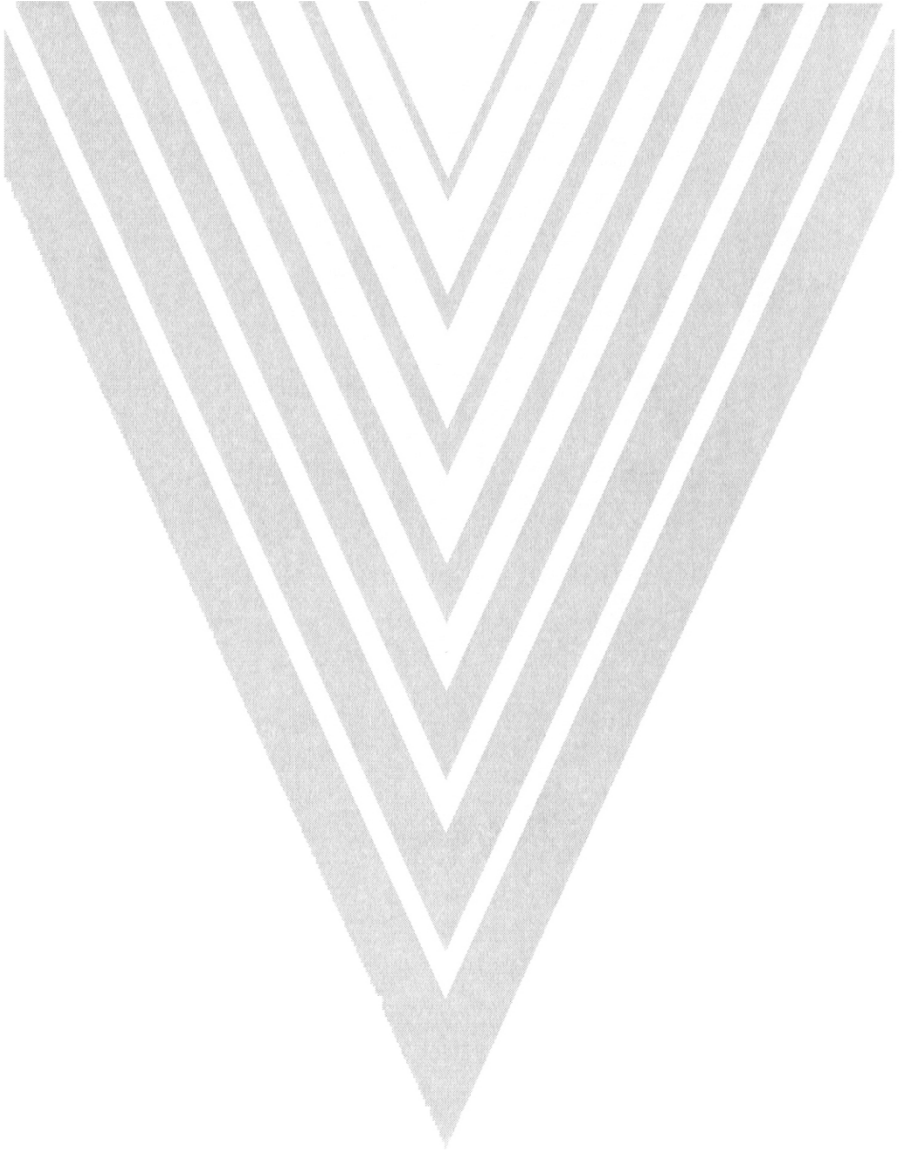

VERTEX WATER PRODUCTS Montclair, CA

PWCM-6 08/15

Copyright 2009 VERTEX INDUSTRIALS, INC.

